

Glazing Vision Ltd

Saw Mills Road

Diss

Norfolk IP22 4RG

Tel: 0333 8000 881 Fax: 0333 8000 882

e-mail: sales@glazing-vision.co.uk

website: www.glazing-vision.co.uk



Agrément Certificate

12/4895

Product Sheet 1

GLAZING VISION ROOFLIGHTS

FLUSHGLAZE ROOFLIGHTS

This Agrément Certificate Product Sheet⁽¹⁾ relates to Flushglaze Rooflights, for use on flat and sloping roof and wall (up to three sides) installations of new and existing domestic buildings, to provide natural light.

(1) Hereinafter referred to as 'Certificate'.

CERTIFICATION INCLUDES:

- factors relating to compliance with Building Regulations where applicable
- factors relating to additional non-regulatory information where applicable
- independently verified technical specification
- assessment criteria and technical investigations
- design considerations
- installation guidance
- regular surveillance of production
- formal three-yearly review.

KEY FACTORS ASSESSED

Light and solar transmittance — the products provide a means of natural lighting to the interior of a building (see section 6).

Thermal properties — U values can meet the Building Regulations requirements depending on frame/glass/size combination (see section 7).

Condensation risk — the risk of condensation on the product's internal surface will depend on the product selected and the building type (see section 8).

Strength and stability — the products will resist imposed snow loads and wind loads (see section 9).

Weathertightness — the products are weathertight (see section 10).

Behaviour in relation to fire — the glazing used in the rooflights can be considered as non-combustible material and therefore unrestricted under the Building Regulations (see section 11).

Durability — with appropriate maintenance, the life of the rooflights should be at least 20 years in non-corrosive environments. Any slight external colour change or surface dulling of the frame that might occur will be uniform over the visible surfaces of the frame (see section 16).



The BBA has awarded this Certificate to the company named above for the products described herein. These products have been assessed by the BBA as being fit for their intended use provided they are installed, used and maintained as set out in this Certificate.

On behalf of the British Board of Agrément

Handwritten signature of Sean Moriarty in black ink.

Date of First issue: 27 February 2013

Sean Moriarty — Head of Approvals
Energy and Ventilation

Handwritten signature of Greg Cooper in black ink.

Greg Cooper
Chief Executive

The BBA is a UKAS accredited certification body — Number 113. The schedule of the current scope of accreditation for product certification is available in pdf format via the UKAS link on the BBA website at www.bbacerts.co.uk

Readers are advised to check the validity and latest issue number of this Agrément Certificate by either referring to the BBA website or contacting the BBA direct.

British Board of Agrément

Bucknalls Lane

Watford

Herts WD25 9BA

tel: 01923 665300

fax: 01923 665301

e-mail: mail@bba.star.co.uk

website: www.bbacerts.co.uk

©2013

Regulations

In the opinion of the BBA, Flushglaze Rooflights, if installed, used and maintained in accordance with this Certificate, will meet or contribute to meeting the relevant requirements of the following Building Regulations (the presence of a UK map indicates that the subject is related to the Building Regulations in the region or regions of the UK depicted):



The Building Regulations 2010 (England and Wales) (as amended)

Requirement: A1	Loading
Comment:	The products will have sufficient strength and stiffness to sustain the design loads. See sections 9.1, 9.3 and 9.4 of this Certificate.
Requirement: B2(1)	Internal fire spread (linings)
Comment:	The glazing used in the products can be regarded as non-combustible material and therefore can be taken as having a Class A1 classification. See section 11.1 of this Certificate.
Requirement: B4(2)	External fire spread
Comment:	When used in rooflights, unwired glass at least 4 mm thick can be regarded as having an AA designation. See sections 11.2 and 11.3 of this Certificate.
Requirement: C2(b)	Resistance to moisture
Comment:	The rooflights will not adversely affect the resistance of the roof to the passage of moisture. The products provide adequate resistance to the ingress of precipitation. See section 10.1 of this Certificate.
Requirement: C2(c)	Resistance to moisture
Comment:	The risk of surface condensation on the products will depend on the building humidity class and the product selected. See sections 8.1 to 8.3 of this Certificate.
Requirement: L1(a)(i)	Conservation of fuel and power
Comment:	See sections 6.2 and 7 of this Certificate.
Regulation: 7	Materials and workmanship
Comment:	The products are acceptable when used in accordance with this Certificate. See section 16.1 and the <i>Installation</i> part of this Certificate.
Regulation: 26	CO₂ emission rates for new buildings
Comment:	See sections 6.2 and 7 of this Certificate.



The Building (Scotland) Regulations 2004 (as amended)

Regulation: 8(1)(2)	Fitness and durability of materials and workmanship
Comment:	The use of the products satisfies the requirements of this Regulation. See sections 15.1, 16.1 and the <i>Installation</i> part of this Certificate.
Regulation: 9	Building standards applicable to construction
Standard: 1.1(b)	Structure
Comment:	The products will have sufficient strength and stiffness to sustain design loads, with reference to clause 1.1.1 ⁽¹⁾ . See sections 9.1, 9.3 and 9.4 of this Certificate.
Standard: 2.5	Internal linings
Comment:	The glazing, as part of the ceiling lining, is non-combustible, with reference to clause 2.5.1 ⁽¹⁾ . See section 11.1 of this Certificate.
Standard: 2.8	Spread from neighbouring buildings
Comment:	When used in rooflights, glass at least 4 mm thick is classified as 'low vulnerability' material, with reference to clause 2.8.1 ⁽¹⁾ . See sections 11.2 and 11.3 of this Certificate.
Standard: 3.10	Precipitation
Comment:	The products provide adequate resistance to the ingress of precipitation, with reference to clause 3.10.1 ⁽¹⁾ . See section 10.1 of this Certificate.
Standard: 3.15	Condensation
Comment:	The risk of surface condensation on the products will depend on the building humidity class and the products selected, with reference to clauses 3.15.1 ⁽¹⁾ and 3.15.4 ⁽¹⁾ . See sections 8.1 to 8.3 of this Certificate.
Standard: 3.16	Natural lighting
Comment:	The products can contribute to meeting this Standard.
Standard: 6.1(b)	Carbon dioxide emissions
Standard: 6.2	Building insulation envelope
Comment:	With reference to clauses 6.1.2 ⁽¹⁾ , 6.1.6 ⁽¹⁾ , 6.2.1 ⁽¹⁾ , 6.2.6 ⁽¹⁾ , 6.2.7 ⁽¹⁾ , 6.2.8, 6.2.9 ⁽¹⁾ , 6.2.11 ⁽¹⁾ and 6.2.13 ⁽¹⁾ , see sections 6.2 and 7 of this Certificate.
Standard: 7.1(a)(b)	Statement of sustainability
Comment:	The products can contribute to meeting the relevant requirements of Regulation 9, Standards 1 to 6 and therefore will contribute to a construction meeting a bronze level of sustainability as defined in this Standard. In addition the products can contribute to a construction meeting a higher level of sustainability as defined in this Standard, with reference to clauses 7.1.4 ⁽¹⁾ [Aspects 1 ⁽¹⁾ and 2 ⁽¹⁾], 7.1.6 ⁽¹⁾ [Aspects 1 ⁽¹⁾ and 2 ⁽¹⁾] and 7.1.7 ⁽¹⁾ [Aspect 1 ⁽¹⁾]. See section 7 of this Certificate.

Regulation:	12	Building standards applicable to conversions
Comments:	All comments given for the products under Regulation 9, Standards 1 to 6 also apply to this Regulation, with reference to clause 0.12.1 ⁽¹⁾ and Schedule 6 ⁽¹⁾ . (1) Technical Handbook (Domestic).	



The Building Regulations (Northern Ireland) 2012

Regulation:	23(a)(i)(iii)(b)	Fitness of materials and workmanship
Comment:	The products are acceptable. See section 16.1 and the <i>Installation</i> part of this Certificate.	
Regulation:	28(b)	Resistance to moisture and weather
Comment:	The products will not adversely affect the resistance of the roof to the passage of moisture. See section 10.1 of this Certificate.	
Regulation:	30	Stability
Comment:	The products have sufficient strength and stiffness to sustain the design loads. See sections 9.1, 9.3 and 9.4 of this Certificate.	
Regulation:	34	Internal fire spread – Linings
Comment:	The glazing used in the products can be regarded as non-combustible material and therefore can be taken as having a Class A1 classification. See section 11.1 of this Certificate.	
Regulation:	36(b)	External fire spread
Comment:	When used in rooflights, unwired glass at least 4 mm thick can be regarded as having an AA designation. See sections 11.2 and 11.3 of this Certificate.	
Regulation:	39(a)(i)	Conservation measures
Regulation:	40(2)	Target carbon dioxide emission rate
Comment:	See sections 6.2 and 7 of this Certificate.	

Construction (Design and Management) Regulations 2007

Construction (Design and Management) Regulations (Northern Ireland) 2007

Information in this Certificate may assist the client, CDM co-ordinator, designer and contractors to address their obligations under these Regulations.

See section: 3 *Delivery and site handling* (3.5) of this Certificate.

Additional Information

NHBC Standards 2013

In the opinion of the BBA, the use of Flushglaze Rooflights, in relation to this Certificate is not subject to the requirements of these Standards.

Technical Specification

1 Description

1.1 Flushglaze fixed rooflights comprise sealed glazed units fixed in a polyester powder coated aluminium frame [grey finish on the outside and white finish on the inside; other colours are available (outside the scope of this Certificate)] and are available as double- or triple-glazed units for installation on flat or pitched roofs (minimum pitch 3°, minimum pitch for walk-on 1°) or wall mounted (up to three sides). The sealed units are fixed to the frame using structural adhesive sealant. The T-shaped frame is fixed to a timber kerb (outside the scope of this Certificate) and angled sections to the wall. For typical installations see Figures 1, 2, 3, 4 and 5.

1.2 Double-glazed units are available as:

- square, rectangular or circular shapes
- single or multi-part units
- standard, walk-on or fire-rated.

1.3 Standard 28 mm double-glazed units comprise 6 mm clear toughened outer pane, 16 mm Argon filled cavity (16 mm silicone sealed warm edge Swisspacer black spacer) and 6 mm clear low-E toughened inner pane. For standard sizes see Table 1.

Figure 1 Wall mounted Flushglaze



Figure 2 Walk-on Flushglaze



Figure 3 Multi-part Flushglaze



Figure 4 Typical Flushglaze installations

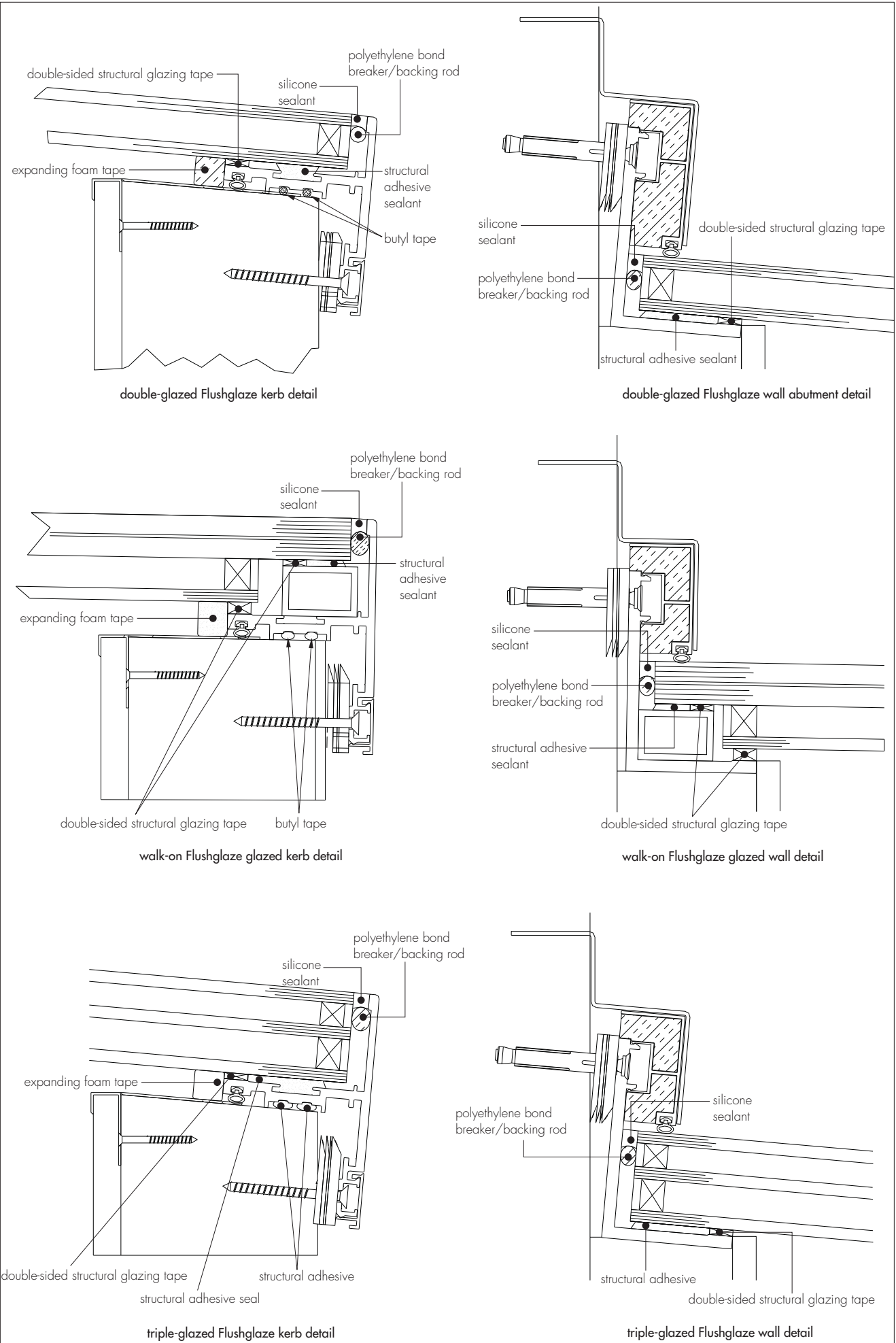

Figure 5 Typical fire-rated Flushglaze installation

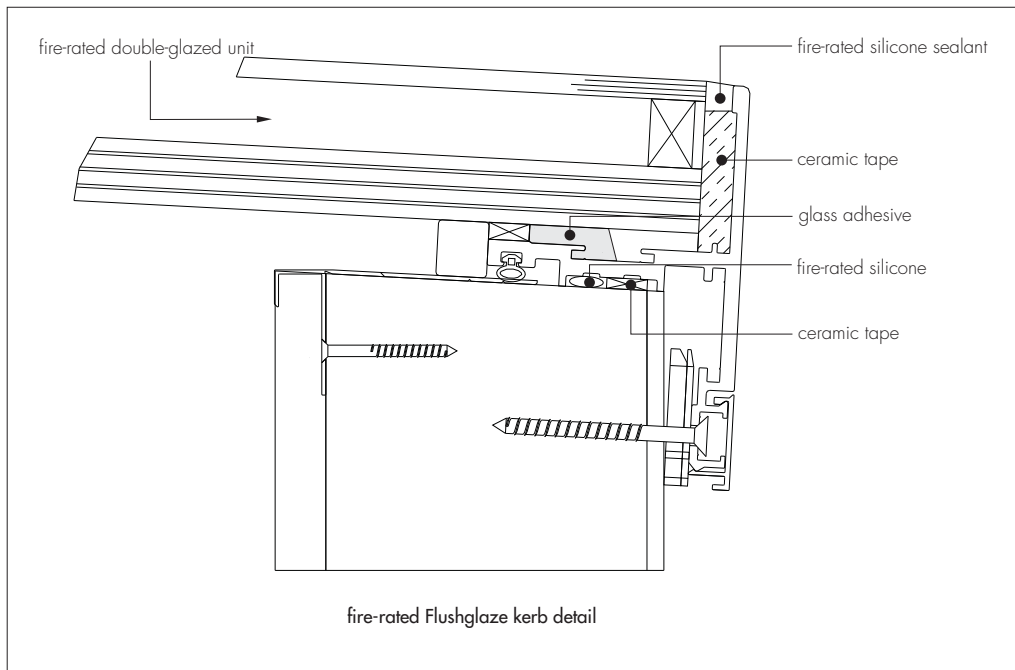

Table 1 Standard sizes of single double-glazed units

750 mm x 750 mm
900 mm x 900 mm
900 mm x 1200 mm
1000 mm x 1000 mm
1000 mm x 1500 mm
1200 mm x 1200 mm
Circular, maximum diameter 1000 mm

1.4 The maximum sizes of double-glazed Flushglaze Rooflights supported on four kerb edges are:

- maximum size single pane 1.5 m² up to 5° kerb pitch
- maximum size single pane 1.5 m² (with toughened inner and outer pane) at kerb pitches $\geq 10^\circ$
- maximum size single pane 1.5 m² (with annealed laminated inner pane) at kerb pitches $\geq 10^\circ$.

1.5 Multiple units are joined together in three ways (see Figure 6), the seal between units comprising:

- Silicone seal joint — low modulus, neutral cure silicone weatherseal (black), applied on site and polyethylene bond breaker/backing rod, applied on site. Maximum length of silicone seal joint 1300 mm (with toughened inner and outer pane) and 900 mm (with annealed laminated inner pane).
- Back-to-back aluminium L-section — the polyester powder coated aluminium sections vary depending on the rooflights' specification and rest on the timber kerb. Sections are held together with M6 countersunk stainless steel sexbolts at approximately 600 mm centres. An obscured band is applied to the inner surface of the glazed unit. The seal between units comprises low modulus, neutral cure silicone weatherseal (black), applied on site and polyethylene bond breaker/backing rod, applied on site. Maximum length of back-to back aluminium L-section is 1500 mm.
- Glass fins — the depth depends on the overall rooflight dimensions and glass specification. Packing (8 mm thick) is positioned at 600 mm centres. The glass fins are supported by stainless steel brackets, which are fixed to kerb/timber trimmers (outside the scope of this assessment) screws. The seal between units comprises a silicone seal joint [low modulus, neutral cure silicone weatherseal (black)], applied on site and polyethylene bond breaker/backing rod, applied on site. Maximum length of glass fin is 1500 mm.

1.6 Walk-on 43.5 mm double-glazed units comprise a 21.5 mm toughened laminated outer pane [comprising two off 10 mm clear toughened and heat soak tested panes laminated with a 1.5 mm C.I.P. (cast-in-place) Interlayer], 16 mm Argon filled cavity (16 mm silicone sealed warm edge Swisspacer black spacer) and 6 mm clear Low-E toughened inner pane. The outer surface of the toughened glass can be covered with 8 mm non-slip frit dots (40% coverage) or sandblasted. The rooflights can be installed on flat or pitched roofs (minimum pitch 1°, built into the kerb) or wall mounted (up to three sides). Rooflights are available as square, rectangular or circular and as single or multiple units. For standard sizes see Table 2.

Figure 6 Joints between glazing units

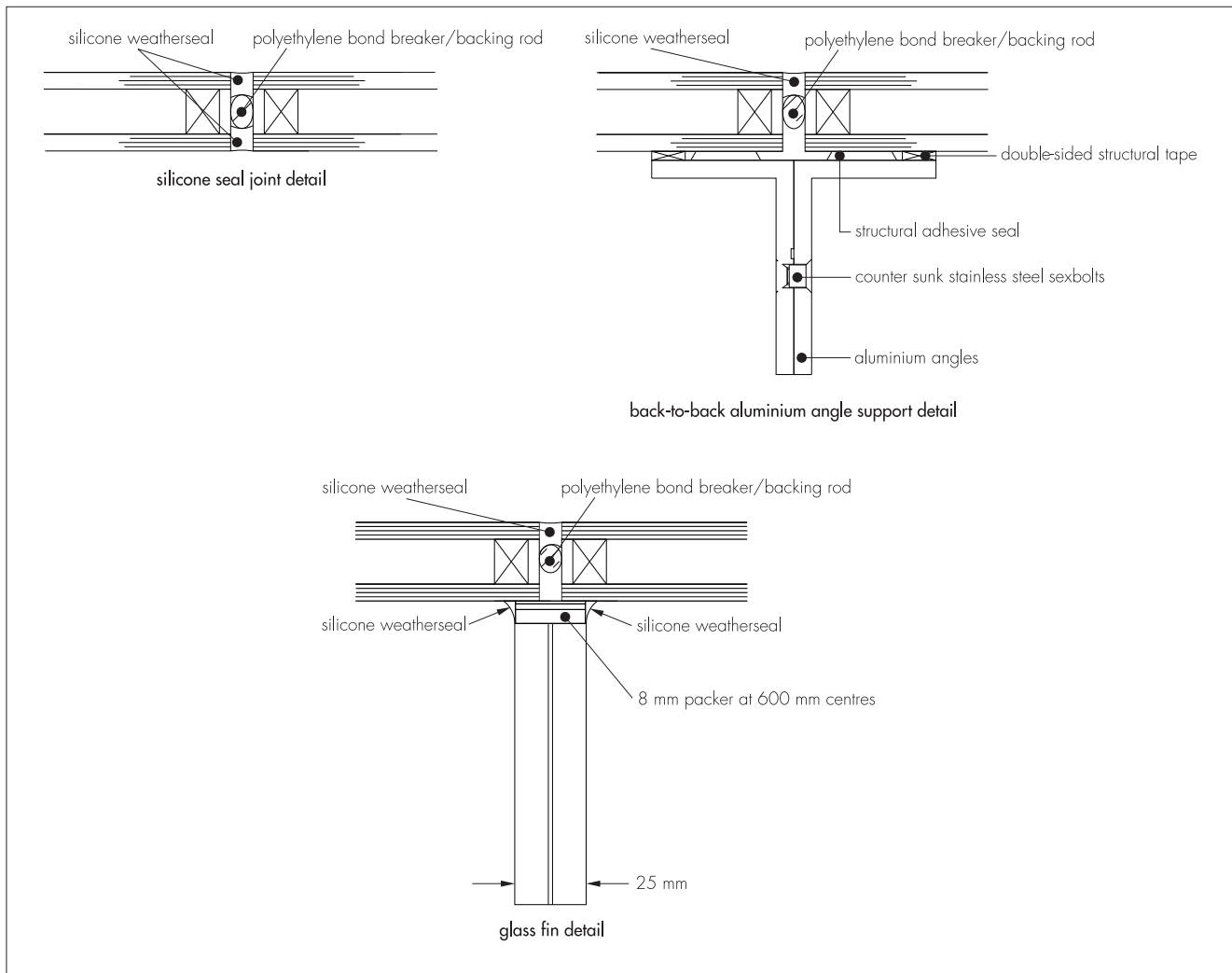

Table 2 Standard sizes of Walk-on units

1000 mm x 1500 mm
Circular, maximum diameter 1000 mm

1.7 The maximum sizes of Walk-on Flushglaze are:

- Single pane 1000 mm by 1500 mm (maximum 1.5 m²)
- Multiple double-glazed units up to 1.5 m² comprise 25.5 mm toughened laminated outer pane (comprising two off 12 mm clear toughened and heat soak tested panes laminated with a 1.5 mm C.I.P. interlayer), 16 mm Argon filled cavity (16 mm silicone sealed warm edge Swisspacer black spacer) and 6 mm clear Low-E toughened inner pane with aluminium angles.

1.8 Walk-on multiple units are joined together with back-to-back aluminium L-section. The polyester powder coated aluminium sections vary, depending on the rooflights' specification, and rest on the timber kerb. Sections are held together with M6 countersunk stainless steel sexbolts at 600 mm centres. An obscured band is applied to the inner surface of the glazed unit. The seal between units comprises low modulus, neutral cure silicone weatherseal (black), applied on site and polyethylene bond breaker/backing rod, applied on site. The maximum length of back-to-back aluminium L-section is 4000 mm.

1.9 Fire-rated 45 mm double-glazed units comprise a 6 mm clear with low-E toughened outer pane, 20 mm air filled cavity (20 mm steel spacer) and 19 mm clear laminated Pyrobel inner pane. The maximum size of kerb: 1000 by 1500 mm.

1.10 Triple-glazed units are available as:

- square, rectangular or circular shapes
- single or multiple units
- standard.

1.11 Standard 46 mm triple-glazed units comprise 6 mm clear toughened outer pane, 12 mm Argon filled cavity (12 mm silicone sealed warm edge Swisspacer black spacer), 6 mm soft low-E coated clear toughened centre pane,

16 mm argon filled cavity (16 mm silicone sealed warm edge Swisspacer black spacer) and 6 mm soft coated Low-E clear toughened inner pane. For standard sizes see Table 3.

Table 3 Standard sizes of single triple-glazed units

750 mm x 750 mm
900 mm x 900 mm
900 mm x 1200 mm
1000 mm x 1000 mm
1000 mm x 1500 mm
Circular, maximum diameter 1000 mm

1.12 Triple-glazed multiple units are joined together in three ways:

- seal between units: silicone seal joint — low modulus, neutral cure silicone weatherseal (black), applied on site and polyethylene bond breaker/backing rod, applied on site. The reverse is repeated on the other triple-glazed unit. The maximum length of silicone seal joint 1300 mm.
- back-to-back aluminium L-section. The polyester powder coated aluminium sections vary, depending on the rooflights' specification and rest on the timber kerb. Sections are held together with M6 countersunk stainless steel sexbolts at 600 mm centres. An obscured band is applied to the inner surface of the glazed unit. The seal between units comprises a silicone seal joint with low modulus, neutral cure silicone weatherseal (black), applied on site and polyethylene bond breaker/backer rod, applied on site. The maximum length of back-to-back aluminium L-section is 1500 mm.
- glass fins: the depth depends on the overall rooflight dimensions and glass specification. Packing (8 mm thick) is positioned at 600 mm centres and a silicone bead is applied either side of the packer. The glass fins are supported by stainless steel brackets, which are fixed to kerb/timber trimmers (outside the scope of this assessment). The seal between units comprises a silicone seal joint [low modulus, neutral cure silicone weatherseal (black)], applied on site and polyethylene bond breaker/backing rod, applied on site. Maximum length of glass fin is 1500 mm.

1.13 Polyester powder coated aluminium frame profiles are available in two sizes, for installation on roofs and angle profiles for wall mounted installations.

2 Manufacture

2.1 Aluminium profiles are polyester powder coated, cut to size and bonded or welded together. Glazing units are fixed to the frames in the factory.

2.2 As part of the assessment and ongoing surveillance of product quality, the BBA has:

- agreed with the manufacturer the quality control procedures and product testing to be undertaken
- assessed and agreed the quality control operated over batches of incoming materials
- monitored the production process and verified that it is in accordance with the documented process
- evaluated the process for management of nonconformities
- checked that equipment has been properly tested and calibrated
- undertaken to carry out the above measures on a regular basis through a surveillance process, to verify that the specifications and quality control operated by the manufacturer are being maintained.

2.3 The management system of Glazing Vision Ltd has been assessed and registered as meeting the requirements of BS EN ISO 9001 : 2008 by QMS International plc (Certificate GB17775).

3 Delivery and site handling

3.1 The Certificate holder's recommendations for site handling and installation are provided with each delivery.

3.2 The glazing units and frames are delivered to site ready for assembly, wrapped in bubble wrap protective sheet.

3.3 If the glazing units are to be stored on site they should be stacked on edge, with an air gap between each unit, on a protected, dry, level surface under cover.

3.4 Before installation, the frames should be laid on timber packers placed on a level surface to avoid damage to finishes and accessories.

3.5 Smaller units may be manhandled to roof level but larger units will need to be craned into position.

3.6 Glass fins must be kept in an upright position to prevent them from sagging.

3.7 Damaged or broken units must not be used. Units must be kept away from contamination such as cement dust.

Assessment and Technical Investigations

The following is a summary of the assessment and technical investigations carried out on Flushglaze Rooflights.

Design Considerations

4 Use

4.1 Flushglaze Rooflights are suitable for use on flat and pitched roofs (pitch between 1° and 70°) of domestic buildings, to provide natural light. New roofs should be designed in accordance with BS 6229 : 2003.

4.2 The rooflights are suitable for most existing roofs but it is important that the roof is checked by a suitably qualified and experienced individual to ensure that the possible removal of roof-supporting members will not cause undue weakening of the structure and that it can bear any possible additional loads imposed upon it by the installation of the products.

5 Practicability of installation

The products are designed to be installed by a competent general builder, or a contractor, experienced with these types of products.

The rooflights can be installed using the methods and procedures within this Certificate and in accordance with the recommendations given in the Certificate holder's installation guide.

6 Light and solar transmittance

6.1 For design purposes, the approximate light and solar transmittance characteristics of the glazing can be taken from SAP 2009, Table 6b and may be used in SAP and SBEM calculations.

6.2 The methods outlined in CIBSE Guide A (2006) *Environmental design*, Sections 5.7 and 5.8 and Appendix 5 should be used if the total solar gain of the building incorporating the products presents a significant heat input.

7 Thermal properties

7.1 When considering rooflight requirements, designers should refer to the detailed guidance contained in the documents supporting the national Building Regulations. The values quoted in Tables 4, 5 and 6, which should be used in accordance with section 7.2 of this Certificate, indicate that typical design U values referred to in those supporting documents can be met (see section 7.4).

Table 4 Thermal performance of junctions

Junction detail	Linear thermal transmittance, ψ -value ($\text{W}\cdot\text{m}^{-1}\cdot\text{K}^{-1}$)				
	Kerb mounted ψ_{km}	Wall mounted ψ_{wm}	Glass fin ψ_{gf}	Back-to-back ψ_{bb}	Silicone joint ψ_{sj}
Double-glazed ⁽¹⁾	0.12	0.41	0.18	0.28	0.18
Walk-on ⁽²⁾	0.13	0.50	—	0.69	—
Triple-glazed ⁽³⁾	0.13	0.42	0.16	0.21	0.14
Fire-rated ⁽⁴⁾	0.18	—	—	—	—

(1) Double-glazed unit: 6/16/6 (float/Argon 90%/float with Optitherm S4) or 6/14/8.8 (float/Argon 90%/two 4 mm with laminate) using V Swisspacer.
(2) Walk-on glazed unit: 21.5/16/6 (two 10 mm float and laminate/Argon 90%/float with Optitherm S4) or 21.5/14/8.8 (two 10 mm float with laminate/Argon 90%/two 4 mm with laminate) using V Swisspacer
(3) Triple-glazed unit: 6/12/6/16/6 (float/Argon 90%/float with Optitherm S4/Argon 90%/float with Optitherm S4) using V Swisspacer
(4) Fire-rated unit: 6/20/19 (float with Optitherm S4/Argon 90%/four 4 mm with laminate) using stainless steel spacer.

Table 5 Thermal performance of glazing

Glazing type	Thermal transmittance of glazing U_g ($W \cdot m^{-1} \cdot K^{-1}$)	
	Horizontal heat flow ⁽¹⁾	Vertical heat flow ⁽²⁾
Double-glazed	1.19	1.84
Walk-on	1.17	1.79
Triple-glazed	0.68	0.93
Fire-rated	1.20	1.75

- (1) Glazing U value used to generate $U_{\text{rooflight}}$ for comparison with Building Regulations for England and Wales and Northern Ireland, see Table 7 of this Certificate.
 (2) Glazing U value used to generate $U_{\text{rooflight}}$ for comparison with Building Regulations for Scotland and for entry into SAP or SBEM, see Table 7 of this Certificate.

Table 6 Profile dimensions

Junction detail	Profile widths, b (m)				
	Kerb mounted b_{km}	Wall mounted b_{wm}	Glass fin b_{gf}	Back-to-back b_{bb}	Silicone joint b_{sj}
	0.000	0.41	0.033	0.102	0.032

7.2 U values can be calculated using the following equations and values given in Tables 4, 5 and 6.

For comparison with Building Regulations and for entry into SAP and SBEM, the total thermal transmittance of the Flushglaze rooflight, $U_{\text{rooflight}}$ is given by:

$$U_{\text{rooflight}} = \frac{U_g A_g + \psi_{km} l_{km} + \psi_{wm} l_{wm} + \psi_{gf} l_{gf} + \psi_{bb} l_{bb} + \psi_{sj} l_{sj}}{A_{\text{opening}}}$$

Where:

- U_g is the thermal transmittance of the glazing, given in Table 5.
- A_g is the area of the glazing (m^2).
- ψ_{km} is the linear thermal transmittance of the kerb mounting (if present), given in Table 4.
- l_{km} is the junction length of kerb mounting (m).
- ψ_{wm} is the linear thermal transmittance of the wall mounting (if present), given in Table 4.
- l_{wm} is the junction length of wall mounting (m).
- ψ_{gf} is the linear thermal transmittance of the glass fin (if present), given in Table 4.
- l_{gf} is the junction length of glass fin (m).
- ψ_{bb} is the linear thermal transmittance of the back to back joint (if present), given in Table 4.
- l_{bb} is the junction length of the back to back joint (m).
- ψ_{sj} is the linear thermal transmittance of the silicone joint (if present), given in Table 4.
- l_{sj} is the junction length of the silicone joint (m).
- A_{opening} is the area of the opening of the roof (m^2).

Notes:

- (1) For comparison with England and Wales and Northern Ireland Building Regulations U_g from column 2 of Table 5 should be used; for Scottish Building Regulations the U_g from the third column of Table 5 should be used.
- (2) For purposes of input into SBEM, the surface area ratio S shall be taken as 1.

7.3 Rooflights with U values, $U_{\text{rooflight}}$ lower than (or the same as, for new dwellings in Scotland) the relevant 'notional' value specified in Table 7 of this Certificate will contribute to a building meeting its Target Emission Rate. Rooflights with higher U values may require additional energy saving measures in the building envelope and/or services. For existing buildings, extensions, conversions, etc, rooflights will be acceptable where they do not exceed the relevant U value in Table 7.

7.4 Care must be taken in the design and detailing of upstand/roof junctions to minimise excessive heat loss.

Table 7 Typical design U values⁽¹⁾ (developed areas) for rooflights

Building type	England and Wales ⁽²⁾	Scotland ⁽³⁾	Northern Ireland ⁽²⁾
Notional dwelling	2.0	1.5	2.0
New-build limit (dwellings)	2.0	1.8	2.0
Existing dwelling	1.6	1.6	1.6

(1) Flexible approaches on existing buildings and individual limit values are given in the Approved Documents (England and Wales), Technical Handbook (Scotland), and Technical Booklet (Northern Ireland).

(2) Values to be compared with rooflights in the vertical plane.

(3) Values to be compared with rooflights in the horizontal plane.

8 Condensation risk



8.1 Modelling of the rooflights in accordance with BS EN ISO 10211 : 2007 indicates the minimum temperature factors shown in Table 8.

Table 8 Minimum temperature factors

Junction detail	Minimum temperature factor, f_{Rsi}				
	Kerb mounted	Wall mounted	Glass fin	Back-to-back	Silicone joint
Double-glazed	0.42	0.23	0.72	0.81	0.60
Walk-on	0.43	0.24	—	0.88	—
Triple-glazed	0.45	0.25	0.80	0.89	0.71
Fire-rated	0.44	—	—	—	—

8.2 The risk of condensation forming on an internal surface of the rooflight is dependent on its temperature and the temperature and humidity of the adjacent air. The risk will be minimal when the rooflight's minimum temperature factor (see Table 8) exceeds that shown in Table 9, for the relevant building type.

Table 9 Minimum temperature factors⁽¹⁾ to minimise the risk of surface condensation

Humidity class	Building type	Temperature factors for 20°C internal temperature and humidity range in EN ISO 13788 : 2002, Figure A.1 (section 5.4)
1	Dwellings with low occupancy	0.41 – 0.57
2	Dwellings with high occupancy	0.58 – 0.71

(1) The ratio of temperature drop between the internal rooflight surface and the external environment and the total temperature drop between internal and external environments.

8.3 Where the temperature factors given in Table 8 are less than those given in Table 9 for the relevant building type, there is a risk of surface condensation forming. However, limited intermittent condensation, appearing initially on the kerb, will not be detrimental to the rooflight. By way of comparison, minimum temperature factors for typical PVC-U windows are between 0.50 and 0.65.

8.4 In all cases, the risk of surface condensation can be reduced by limiting activities which produce large amounts of moisture and by providing means for adequate ventilation.

9 Strength and stability



9.1 Tests have shown that resistance to imposed wind loads by the rooflights is dependent on size. As a guide, small rooflights are more resistant to imposed loads. Rooflights, therefore, should be selected according to the loads expected for a particular location and use. The loads must be designed by a suitably qualified and experienced individual in accordance with the requirements of the Buildings Regulations and Standards.

9.2 A rectangular walk-on rooflight was tested with a uniformly distributed load (UDL) of 1.5 kN·m⁻² plus an ultimate positive pressure of 2500 Pa and a negative pressure of 1000 Pa. See Table 10 for an example of the allowable pressures.

Table 10 Resistance to wind loads (+UDL 1.5 kN·m⁻²)

Rooflight (mm)	Ultimate downward pressure (Pa)	Ultimate upward pressure (Pa)	Allowable downward pressure ⁽¹⁾ (Pa)	Allowable upward pressure ⁽¹⁾ (Pa)
3345 x 1492 ⁽²⁾	2500	1000	833	333

(1) Derived by applying a global safety factor of 3 on ultimate values.

(2) Outer pane: toughened laminated glass outer pane comprising two 12 mm clear toughened and heat soak tested panes laminated together with a 1.5 mm C.I.P. inert layer.



9.3 The magnitude of the actual snow load imposed will depend upon a number of factors, such as height above sea level, geographical location, roof arrangement and type of rooflights. Therefore, it is recommended that BS EN 1991-1-3 : 2003 and its National Annex is used to calculate the actual snow load. The appropriate safety factors must be applied by the building designer.

9.4 The products can be selected to have adequate resistance to wind loads calculated in accordance with BS EN 1991-1-4 : 2005 and its National Annex.

10 Weathertightness



10.1 Rooflights, when installed in accordance with the manufacturer's instructions and sections 17 and 18 of this Certificate, will provide adequate resistance to the ingress of precipitation.

10.2 Particular attention must be paid to the correct fitting of all components. The roof waterproofing system must be carefully dressed up the kerb (outside the scope of this Certificate) to provide a watertight joint between the kerb and the roofdeck.

11 Behaviour in relation to fire



11.1 The glazing in the rooflights is Class A1 by reference to Commission Decision 96/603/EC and can therefore be considered as non-combustible.

11.2 When used, unwired glass at least 4 mm thick can be regarded as having an AA designation.

11.3 When tested generally in accordance with BS EN 1363-1 : 1999, a fire-rated Flushglaze rooflight [measuring 1200 mm by 1200 mm⁽¹⁾ with a double-glazed glazing unit (6 mm clear toughened outer pane, 16 mm steel spacer, air-filled air cavity and a 19 mm Pyrobel Low-E glass with soft coating)] for a duration of 50 minutes achieved Insulation, E; 44 minutes and Integrity, I; 47 minutes and satisfies the integrity and insulation criteria, EI30, of BS EN 1363-1 : 1999 for a minimum period of 30 minutes.

(1) Subsequent Technical Assessment by a Fire Expert extended the size to 1500 mm by 1500 mm.

12 Sound performance

A Walk-on Flushglaze rooflight comprising two glazing units (33 mm low-iron, white laminated, heat-soak-tested, toughened outer pane and a 14 mm air cavity and 8.8 mm clear toughened laminated Low-E coated inner pane) joined with back-to-back angle support, when tested to BS EN ISO 140-3 : 1995 achieved R_w 41 dB.

13 Safety

13.1 Under no circumstances should anyone venture onto a rooflight except the walk-on type. If the rooflight is located on a roof generally accessible to the public, provision must be made to prevent people falling onto the glazed part (by use of, for instance, guard rails).

13.2 When subjected to normal conditions of use, movement of the structure, hygrothermal stresses or vibrations, the rooflights will not collapse or result in falling debris that could cause injury to occupants or passers-by.

13.3 For Walk-on Flushglaze rooflights, care must be taken when walking over the unit, especially in wet conditions and on clear glass. Slip resistant glass was tested to the method in *The Assessment of Floor Slip Resistance, The UK Slip Resistance Guidelines*, Issue 3 November 2005 (see Table 11).

Table 11 Slip resistance

Glass type	Mean surface roughness R_m (μm)	Pedestrian slip potential
Toughened with 8 mm non-slip frit dots (40% coverage)	20	Moderate/low
Toughened, sandblasted	12	Moderate/low

14 Security against intrusion

The sealant arrangement ensures that removal of the glass is difficult from the outside.

15 Maintenance



15.1 If damage occurs, the rooflights can be re-glazed, but this operation should be carried out using the materials recommended by the Certificate holder and approved by the BBA.

15.2 The sealant should be subject to regular inspection and maintenance and replaced if required.

15.3 Cleaning of the rooflight and frame should be carried out using water containing non-detergent soap. To avoid scratching of the surface, only soft cloths should be used when cleaning.

15.4 The external surface of the rooflights cannot be cleaned from the inside of the building. For maintenance and cleaning purposes special precautions must be taken, such as the provision of a catwalk, to allow safe access and to prevent the possibility of falling through the glazing unit.

16 Durability



16.1 Subject to suitable maintenance of the complete rooflight and in particular of the sealant (see section 15.2), the products, when installed in accordance with this Certificate, will have a life of at least 20 years in non-corrosive environments.

16.2 Any slight external colour change or surface dulling of the frame that might occur will be uniform over the visible surfaces of the frame.

Installation

17 General

17.1 Installation of the Flushglaze Rooflights should be carried out in accordance with the Certificate holder's installation instructions.

17.2 Prior to installation of the rooflight, the roof must be checked by means of calculations or testing to ensure that it can carry the additional loads the installation may impose. The roof shall be strengthened as necessary to support the rooflight. This work must be carried out by a suitably qualified and experienced individual.

17.3 The rooflight should be checked dimensionally to ensure fit before the unit is lifted to the roof.

17.4 The kerbs (outside the scope of this Certificate) should be checked for specification and dimensional accuracy. Kerbs should be complete and fully weathertight prior to installation. The correct fall must be built into the kerb to avoid ponding. Information can be obtained from the Certificate holder. The Certificate holder recommends a trial fitting prior to the final installation to ensure correct fit as it becomes extremely difficult to move the units once bonded.

17.5 Multi-part units must not be installed in wet conditions as the site-applied sealant must be applied in dry conditions and temperatures above 5°C. Single units can be installed in wet conditions but care must be taken in handling them.

Wall abutted units

17.6 If the rooflight has a wall abutment, a suitable lead flashing (outside the scope of this Certificate) will be required over the abutment following installation. It is recommended that any chasing of brickwork for flashings is completed prior to installation.

17.7 Temporary battens must be secured to the wall to support the weight of the unit during installation. The battens must be installed in line with the kerbs and removed when installation is complete.

Optional kerb top cover installation

17.8 For units supplied with kerb top cover (outside the scope of this Certificate), lengths are cut to cover the kerb. If the kerb top cover requires bending to suit the pitch of the kerb, this can be achieved by screwing the section to the kerb and gently tapping over using a clean rubber mallet.

17.9 The kerb top cover is cut to size along its length to leave a dimension of 40 mm between the edge of the cover and the outside of the kerb. The kerb top cover extrusion is supplied with five grooves along the underside, which can be used to help guide a saw or similar when trimming the cover to size.

17.10 After all kerb covers have been cut to size and adjusted, they are secured into place. The cover has been designed to accept standard 12 mm plasterboards (outside the scope of this Certificate).

Trial and final fitting

17.11 When installing multi-part units an end section is installed first. If there is a wall abutment positioned along the span, this section must be installed first.

17.12 The first section is lowered into place. Any Flushglaze frame edges must overhang the kerb equally (nominal 22 mm to outer edge of unit) and any wall abutments between 5 mm to 10 mm from the wall face.

17.13 For multi-part units, the next section of the unit is lowered into place. The frames have unique identifications to ensure correct installation (on units without back-to-back angle supports, the identification is located on the underside of the Flushglaze frame).

17.14 Each frame section is aligned with its adjacent frame using the splice plates supplied (except for wall abutments). This step is repeated for all the sections of the multi-part unit.

17.15 When all sections are in place, the centre lines are marked with a pencil onto the kerb/wall. These marks are used to reposition the unit during the final installation.

17.16 Two runs of structural adhesive tape are placed around the underside of all frame sections. Units with wall abutment angle or back to back support angles do not require structural adhesive tape. For fire-rated units one line of ceramic tape and one line of fire-rated silicone are used.

17.17 Expanding foam tape is applied to the underside of glass along all edges (except for fire-rated units).

17.18 Steps in sections 17.12 to 17.14 are repeated to seal the frames to the kerb.

17.19 The Flushglaze frames are secured to the kerb and the wall (outside the scope of this Certificate).

For glass fin installation

17.20 The edge of the Flushglaze frame/wall abutment detail is marked to locate the centre line of the first glass fin, and operations described in sections 17.14 and 17.15 are repeated.

17.21 The glazing units are removed from the kerb/wall.

17.22 A distance of 75 mm is measured to the left of each centre datum line and is marked off on the wall/kerb representing the location for the left-hand edge of the support bracket. The top edge of the back plate of the support bracket should be level with the top surface of the kerb.

17.23 Two brackets, an upper and a lower (angled), per fin are used for glass fins positioned along the pitch. For glass fins positioned across the pitch two right angled brackets are used.

17.24 For brackets mounted to kerbs, the appropriate support bracket is selected and positioned so that the left-hand edge is positioned next to the mark produced in section 17.20 and the top of the bracket sits flush with the kerb. A small pilot hole is drilled for each screw fixing in the kerb and the bracket is fastened to the kerb using woodscrews (outside the scope of this Certificate) and plastic horseshoe packers, ensuring a nominal 5 mm gap from the kerb. This step is repeated for all kerb mounted brackets.

17.25 For brackets mounted under the wall abutment, the appropriate support bracket is selected and is positioned so that the left-hand edge is positioned next to the mark produced in section 17.20 and the top of the bracket sits flush with the top edge of the wooden batten (installed earlier). A hole is drilled for each screw fixing, to suit the wall plugs. The bracket is fastened to the wall using the screws with wall plugs and plastic horseshoe packers ensuring a nominal 5 mm gap from the wall. This step is repeated for all wall mounted brackets.

17.26 When all brackets are fixed to the walls, they are lined with rubber (3 mm thick) and the glass fins are placed inside them.

17.27 If the glass fins have any notches these must be placed upwards (underneath where wall abutments are present) to avoid any contact with the Flushglaze frame. A series of packers (8 mm thick) is placed across the top of the glass fin at a maximum of 600 mm centres, held in place with silicone to prevent glass to glass contact.

17.28 Two runs of butyl tape are placed around the underside of all the frame sections. Units with wall abutment angle or back to back support angles do not require butyl tape. For fire-rated units one line of ceramic tape and one line of fire-rated silicone are used.

17.29 Expanding foam tape is applied to the underside of glass along all edges resting on the kerb (except for fire-rated units) and the frames are sealed to the kerb.

17.30 For multi-part units with back-to-back angle support the angles are locked together using counter sunk fixings.

17.31 The Flushglaze frame is fixed with woodscrews (outside the scope of this Certificate) and the wall abutment with screws and wall plugs/expanding Hilti bolts (for walk-on units, outside the scope of this Certificate), if applicable, ensuring that sufficient horseshoe packers are placed between the kerb/wall and the framework to provide support and prevent frame distortion around each screw fixing.

17.32 For glass fin supported joints, the plastic packers can be twisted to run parallel with the top of the glass fin. A run of matt black silicone is applied along the fin's length between the top of the fin and the underside of the glass to cover the plastic packers.

17.33 When the unit has been securely screwed to the kerb, length(s) of polyethylene backing rod are cut to fit the space between the sections of glass and are pressed into the space and positioned 8 mm below the outer surface of the glass. Silicone is applied to overfill the space and then the excess silicone is removed to finish the joint. The edges of the frames must sit flush and further silicone is applied, if required.

17.34 When the units are secured in place, clip-on covers are fitted over the wall abutments. Insulation (outside the scope of this Certificate) is fitted behind the covers and the clip feature is installed by first engaging the top leg then rotating to engage the bottom leg clicking into place and tapping it gently with a rubber mallet to ensure a secure fit.

17.35 The end plates are bonded into place and any kerb fixing covers are clipped-on by first engaging the top leg and then rotating into place.

17.36 Finally a lead flashing (outside the scope of this Certificate) is fitted over any wall abutments.

Technical Investigations

18 Tests

18.1 Tests were carried out to determine:

- air permeability (BS 6375-1 : 2009)
- watertightness (BS 6375-1 : 2009)
- durability of sealants (generally to BS EN ISO 9047 : 2003)
- resistance to intrusion (generally to BS 6375-3 : 2009)
- resistance to cyclic loads.

18.2 The polyester powder-coating on the aluminium frame was tested to determine:

- resistance to artificial weathering (BS EN ISO 4892-3 : 2000)
- gloss retention after artificial weathering (BS EN ISO 2813 : 2000)
- resistance to salt spray (BS EN ISO 9227 : 2012 and BS EN 1670 : 2007)
- adhesion to substrate (BS EN ISO 2409 : 2007)
- resistance to humidity (BS EN 13523-25 : 2006)
- resistance to scratching (BS EN ISO 1518 : 2001)
- resistance to sulphur dioxide (BS EN ISO 3231 : 1998).

19 Investigations

19.1 The manufacturing process was examined including methods adopted for quality control.

19.2 Assessments and test reports were evaluated relating to the:

- fire performance of the fire-rated rooflights
- weathertightness
- slip resistance.

19.3 Equations for calculating the U values of the rooflights from individual components were generated.

19.4 Thermal performance and temperature factors of glazed rooflights were assessed using thermal simulation with reference to BS EN ISO 10077-2 : 2003, BS EN ISO 10211 : 2007 and BRE Report 497 : 2007 *Conventions for calculating linear thermal transmittance and temperature factors*. Thermal transmittance of the glazing was assessed using BS EN 673 : 2011.

19.5 A user survey was conducted.

Bibliography

- BS 6229 : 2003 *Flat roofs with continuously supported coverings — Code of practice*
- BS 6375-1 : 2009 *Performance of windows and doors — Classification for weathertightness and guidance on selection and specification*
- BS 6375-3 : 2009 *Performance of windows and doors — Classification for additional performance characteristics and guidance on selection and specification*
- BS EN 673 : 2011 *Glass in building — Determination of thermal transmittance (U value) — Calculation method*
- BS EN 1991-1-3 : 2003 *Eurocode 1 : Actions on structures — General actions — Snow loads*
- NA to BS EN 1991-1-3 : 2003 *UK National Annex to Eurocode 1 : Actions on structures — General actions — Snow loads*
- BS EN 1991-1-4 : 2005 *Eurocode 1 : Actions on structures — General actions — Wind actions*
- NA to BS EN 1991-1-4 : 2005 *UK National Annex to Eurocode 1 : Actions on structures — General actions — Wind actions*
- BS EN 1363-1 : 1999 *Fire resistance tests — General requirements*
- BS EN 1670 : 2007 *Building hardware — Corrosion resistance — Requirements and test methods*
- BS EN 13523-25 : 2006 *Coiled coated metals — Test methods — Resistance to humidity*
- BS EN ISO 140-3 : 1995 *Acoustics — Measurement of sound insulation in buildings and of building elements — Laboratory measurement of airborne sound insulation of building elements*
- BS EN ISO 1518 : 2001 *Paints and varnishes — Scratch test*
- BS EN ISO 2409 : 2007 *Paints and varnishes — Cross-cut test*
- BS EN ISO 2813 : 2000 *Paints and varnishes — Determination of specular gloss of non-metallic paint films at 20°, 60° and 85°*
- BS EN ISO 3231 : 1998 *Paints and varnishes — Determination of resistance to humid atmospheres containing sulfur dioxide*
- BS EN ISO 4892-3 : 2000 *Plastics — Methods of exposure to laboratory light sources — Fluorescent UV lamps*
- BS EN ISO 9001 : 2008 *Quality management systems — Requirements*
- BS EN ISO 9047 : 2003 *Building construction — Jointing products — Determination of adhesion/cohesion properties of sealants at variable temperatures*
- BS EN ISO 9227 : 2012 *Corrosion tests in artificial atmospheres — Salt spray tests*
- BS EN ISO 10077-2 : 2003 *Thermal performance of windows, doors and shutters — Calculation of thermal transmittance — Numerical method for frames*
- BS EN ISO 10211 : 2007 *Thermal bridges in building construction — Heat flows and surface temperatures — Detailed calculations*
- EN ISO 13788 : 2002 *Hygrothermal Performance of Building Components and Building Elements - Internal Surface Temperature to Avoid Critical Surface Humidity and Interstitial Condensation - Calculation Methods*

20 Conditions

20.1 This Certificate:

- relates only to the product/system that is named and described on the front page
- is issued only to the company, firm, organisation or person named on the front page — no other company, firm, organisation or person may hold or claim that this Certificate has been issued to them
- is valid only within the UK
- has to be read, considered and used as a whole document — it may be misleading and will be incomplete to be selective
- is copyright of the BBA
- is subject to English Law.

20.2 Publications, documents, specifications, legislation, regulations, standards and the like referenced in this Certificate are those that were current and/or deemed relevant by the BBA at the date of issue or reissue of this Certificate.

20.3 This Certificate will remain valid for an unlimited period provided that the product/system and its manufacture and/or fabrication, including all related and relevant parts and processes thereof:

- are maintained at or above the levels which have been assessed and found to be satisfactory by the BBA
- continue to be checked as and when deemed appropriate by the BBA under arrangements that it will determine
- are reviewed by the BBA as and when it considers appropriate.

20.4 The BBA has used due skill, care and diligence in preparing this Certificate, but no warranty is provided.

20.5 In issuing this Certificate, the BBA is not responsible and is excluded from any liability to any company, firm, organisation or person, for any matters arising directly or indirectly from:

- the presence or absence of any patent, intellectual property or similar rights subsisting in the product/system or any other product/system
- the right of the Certificate holder to manufacture, supply, install, maintain or market the product/system
- actual installations of the product/system, including their nature, design, methods, performance, workmanship and maintenance
- any works and constructions in which the product/system is installed, including their nature, design, methods, performance, workmanship and maintenance
- any loss or damage, including personal injury, howsoever caused by the product/system, including its manufacture, supply, installation, use, maintenance and removal
- any claims by the manufacturer relating to CE marking.

20.6 Any information relating to the manufacture, supply, installation, use, maintenance and removal of this product/system which is contained or referred to in this Certificate is the minimum required to be met when the product/system is manufactured, supplied, installed, used, maintained and removed. It does not purport in any way to restate the requirements of the Health and Safety at Work etc. Act 1974, or of any other statutory, common law or other duty which may exist at the date of issue or reissue of this Certificate; nor is conformity with such information to be taken as satisfying the requirements of the 1974 Act or of any statutory, common law or other duty of care.